

VD82EX

ATEX Compact Vacuum Meter Absolute Pressure 1050 to 1 mbar



VD82 ATEX certified digital vacuum meter with external sensor head to measure absolute pressure in the rough vacuum range.

Used in hazardous areas where explosive vapors are present.

EG prototype certificate:
BVS 06 ATEX E 011
Mark: II 2 G EEX ia IIC T4



Typical Applications

- Measuring absolute pressure in zone 1 hazardous (explosion) areas
- Chemical engineering
- Checking and setup of vacuum pumps
- Laboratory and research
- Analysis and documentation of vacuum pumps and facilities
- Service and maintenance
- Analysis instruments
- Leak tests

Benefits

- External detachable stainless steel sensor head
- Chemically resistant ceramic sensor with FFKM sealing
- High repeatability
- Excellent long-term stability
- Up to 100 h battery life
- Compact, easy to use
- Automatic switch off and continuous operation
- Pressure units mbar, Torr, hPa
- Min/Max memory: Storage and display of high and low values
- Variable vacuum connection using small flange, G1/4 female thread or hose nozzle
- Delivered with protective case, hose nozzle and plug in battery charger



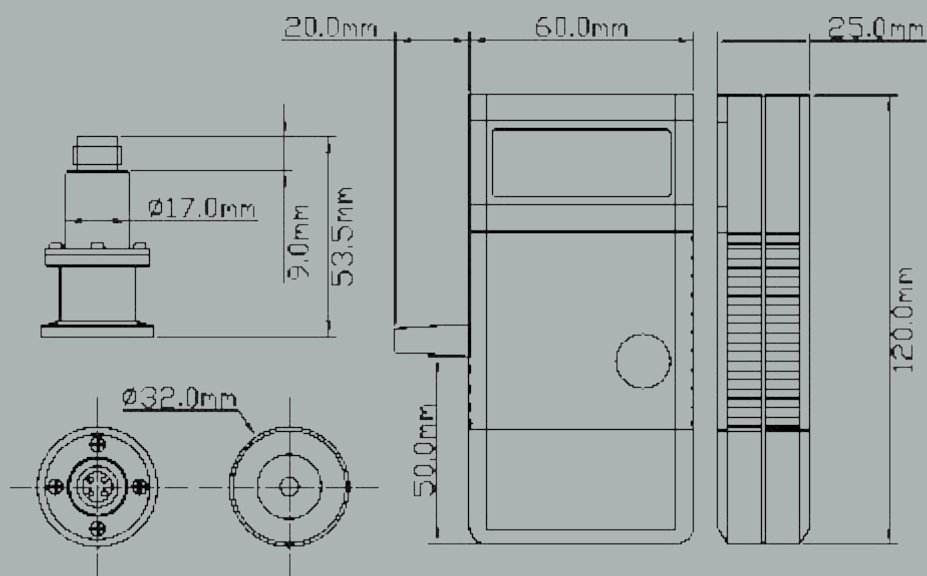

Technical Data

Measuring Principle	Piezo resistive, independent of gas type
Materials In Contact With Vacuum	Stainless steel 1.4305, Al ₂ O ₃ ceramic, FFKM
Measurement Range	1050 - 1 mbar (780 - 1 Torr), max. overpressure 2 bar absolute
Resolution	1 mbar (Torr)
Accuracy	Typ. $\pm 0.3\%$ full scale (linearity, hysteresis, repeatability)
Response Time	20 ms
Measuring Rate	1.0 s
Operating Temperature	0...+40°C
Storage Temperature	-20...+60°C
Power Supply	Integrated 4.8 V Ni-MH rechargeable battery, charging outside of Ex area with plug in charging adaptor, max. charging voltage $U_m=28$ VDC
Electrical Connection	Jack for external plug in charging adaptor
Power Consumption	Approx. 2 mW
Operating Time	Max. 100 h
Display	LCD 12 mm
Sensor Connection	Measuring cable 2 m, plug 4-pole, lockable
Vacuum Connection	DN 16 ISO-KF, G ₁ /4 female thread, hose nozzle 6 - 8 mm
Protection Class	IP40
Weight	Approx. 200 g

Product Codes

- VD82EXP**
 ATEX compact vacuum meter, 1050 to 1 mbar, with protective case, hose nozzle and charging adaptor 230 V
- VD82EXUSP**
 As above, with charging adaptor 115 V